

THIS DOCUMENT CONTAINS PROPRIETARY INFORMATION WHICH IS THE PROPERTY OF QSC AUDIO PRODUCTS. THAT MAY NOT BE DISCLOSED, REPRODUCED OR USED WITHOUT EXPRESS WRITTEN CONSENT FROM QSC AUDIO PRODUCTS.

REVISIONS				
REV	DESCRIPTION	EFF DATE	CHK	APPROVED DATE
I	ENG. RELEASE			
A	PROD. RELEASE PER ECO 6437 MP	2-14-05	SE	DD
A1	REVISED PER ECO 6470 MP	2-08-05		DD
B	REVISED PER ECO 6471 MP	2-11-05		DD

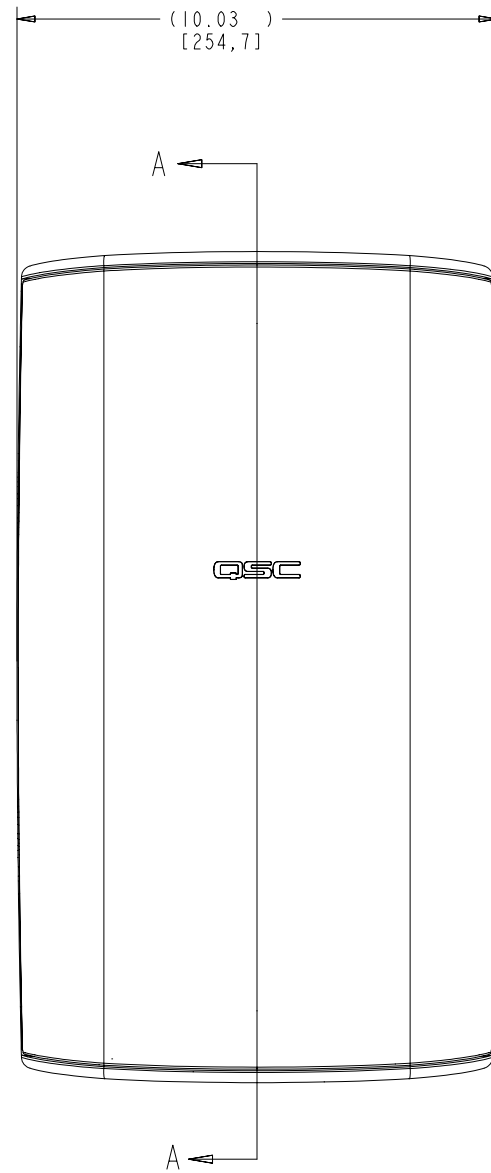

SCALE 0.500

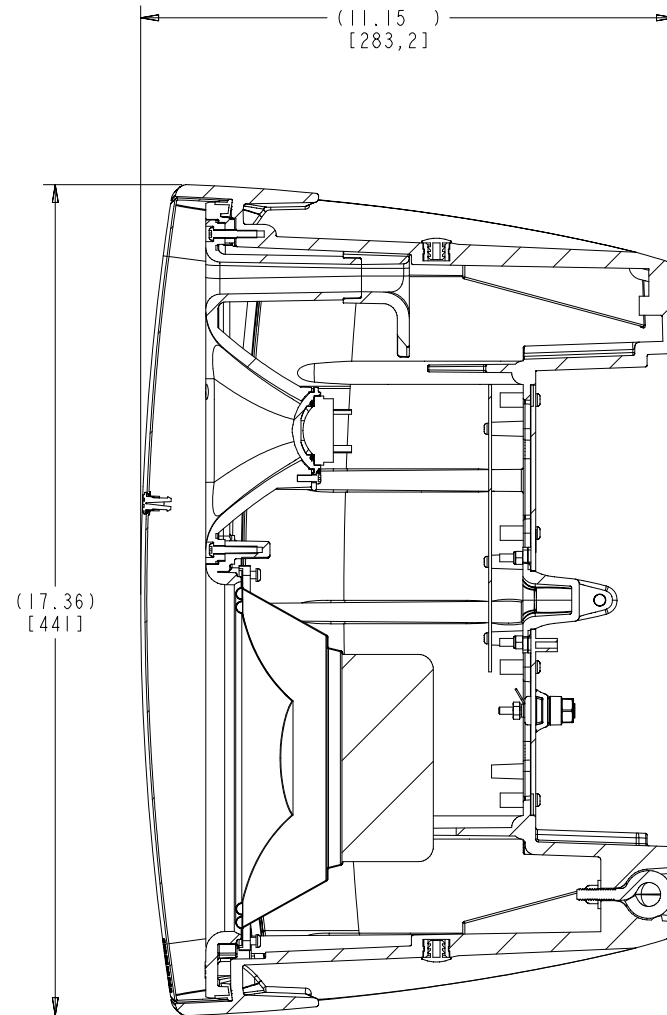

SECTION A-A

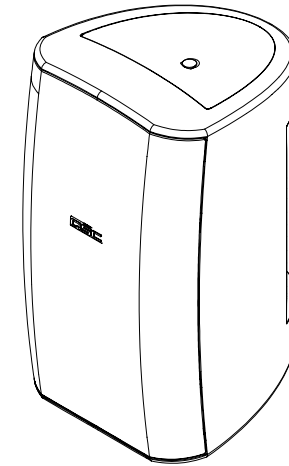

SCALE 0.250

ITEM	PART NUMBER	DESCRIPTION	QTY
40	WP-000409-00	PCB, CROSSOVER, C3-8, SP-61/67, STD	1
39	SP-000067-00	WOOFER, 8", 8 OHM, AD-S82	1
38	SP-000061-00	TWEETER, 1 IN	1
37	SP-000032-00	WAVE-GUIDE, TWEETER, C3-8	1
36	SC-000011-23	SCREW, PHILLIPS, PANHEAD, M4X1.4, 23 L, BLK	16
35	SC-000011-15	SCREW, PHILLIPS, PANHEAD, M4X1.4, 15 L, BLK	8
34	SC-000002-18	SCREW, PHILLIPS, PANHEAD, M4X1.4, 18 L	8
33	SC-000000-12	SCREW, PHILLIPS, PANHEAD, M3.5X1.25, 12 L	6
32	SC-000000-10	SCREW, PHILLIPS, PANHEAD, M3.5X1.25, 10 L	3
31	SB-000004-XX	BAFFLE, C3-8	1
30	SB-000003-XX	BUCKET, AD-S82	1
29	PL-000239-00	GASKET, BAFFLE, NEOPRENE, BLACK	1
28	PL-000238-00	GASKET, WAVE-GUIDE	1
27	PL-000237-00	GASKET, TERMINAL PLATE	1
26	PL-000236-XX	PLUG, INSERT, .375	2
25	PL-000235-00	GASKET, CATCH	1
24	PL-000234-00	GASKET, TWEETER	1
23	PL-000217-01	BASE, BINDING POST, C3-8	1
22	PL-000216-XX	FLARE, PORT, C3-8	1
21	PL-000215-02	NUT, WITH INSERT, BINDING POST	1
20	PL-000215-01	NUT, WITH INSERT, BINDING POST	1
19	PL-000214-00	BACKPLATE, BINDING POST	1
18	PL-000213-XX	BADGE, .45 X 1.87	1
17	PL-000212-XX	RECEPTACLE, BADGE	1
16	NW-250520-04	WASHER, M6, SS	1
15	NW-000026-00	WASHER, SPLIT-LOCK, M4, BRASS	2
14	NW-000024-00	LOCKNUT, M6, W/NYLON, SS	1
13	NW-000023-00	NUT, M4 X 0.7, BRASS	2
12	NW-000022-00	LOCKNUT, M4 X 0.7, W/NYLON, SS	4
11	MS-000211-00	FIBERFILL, POLYESTER, 7.1 X 5.9 X 2.0	2
10	MS-000210-00	FIBERFILL, POLYESTER, 13.4 X 9.9 X 2.0	1
9	HW-000060-00	INSERT, M10 X 1, BRASS	2
8	HW-000041-00	EYE BOLT, 6MM, SS	1
7	HW-000040-00	RETAINER, ID, .312	1
6	CO-000297-00	FASTON, MALE, .210 X .032	2
5	CO-000268-00	POST, BINDING	2
4	CH-000276-00	PIN, CATCH, SS	1
3	CH-000220-XX	PLATE, TERMINAL, C3-8	1
2	CH-000219-XX	CATCH, C3-8	1
1	CH-000215-XX	GRILLE, C3-8	1

BILL OF MATERIALS

UNLESS OTHERWISE SPECIFIED DIMENSIONS ARE IN INCHES.		CONTRACT NO.		QSC QSC AUDIO PRODUCTS, INC. 1675 MACARTHUR BOULEVARD COSTA MESA, CA 92626	
TOLERANCES ARE: DECIMALS DECIMALS ANGLES .XX ±.02 .XXX ±.010 ±1/2 DEBURR EDGES .010 R MAX		APPROVALS	DATE	ASSY, AD-S82	
MATERIAL		DRAWN M. PAKHOMOVA	25-Jan-05		
FINISH		CHECKED R. BALTHAZAR	2-03-05		
DO NOT SCALE DRAWING		MFG ENG P. WRIGHT	1-28-05	SIZE D	CAGE CODE 00PW4
		ISSUED D. DELARM	2-04-05	DWG NO. WP-000430-XX	REV B
		MODEL INFO WP-000430-XX.moin.B.3	SCALE 0.250	DWG NO. WP-000430-XX	SHEET 1 of 2

- COLORS: BLACK PER RD-000120-00, WHITE PER RD-000121-00
- MAXIMUM ALLOWABLE SINKS/BULDGES: .003 INCH
- LOGO ORIENTATION; MAXIMUM ALLOWABLE ANGLE FORM HORIZONTAL: +/- 1 DEGREE
- MAXIMUM ALLOWABLE GAP BETWEEN GRILLE AND BUCKET: .02 INCH
- BUCKET FINISH PER QSC RD-000122-00.
- ASSEMBLE WADDING IN 3 PLACES. APPLY 3M4550 EPOXY TO INSIDE OF BUCKET FOR SECURING 7.1 X 5.9 X 2 WADDING.
- REFERENCE QSC DRIVER SPECIFICATIONS, TWEETER: DOCUMENT RD-000132-00 AND WOOFER: DOCUMENT RD-000133-00, FOR PERFORMANCE CHARACTERISTICS.

PART NUMBER	COLOR
WP-000430-01	BLACK
WP-000430-02	WHITE

NOTE: UNLESS OTHERWISE SPECIFIED

THIS DOCUMENT CONTAINS PROPRIETARY INFORMATION WHICH IS THE PROPERTY OF OSC AUDIO PRODUCTS. THAT MAY NOT BE DISCLOSED, REPRODUCED OR USED WITHOUT EXPRESS WRITTEN CONSENT FROM OSC AUDIO PRODUCTS.

LABEL, SERIAL NUMBER
(RD-000117-00)

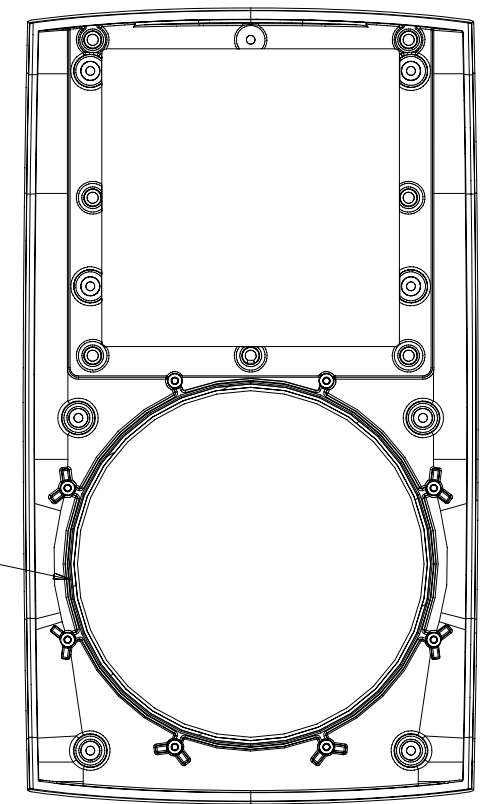
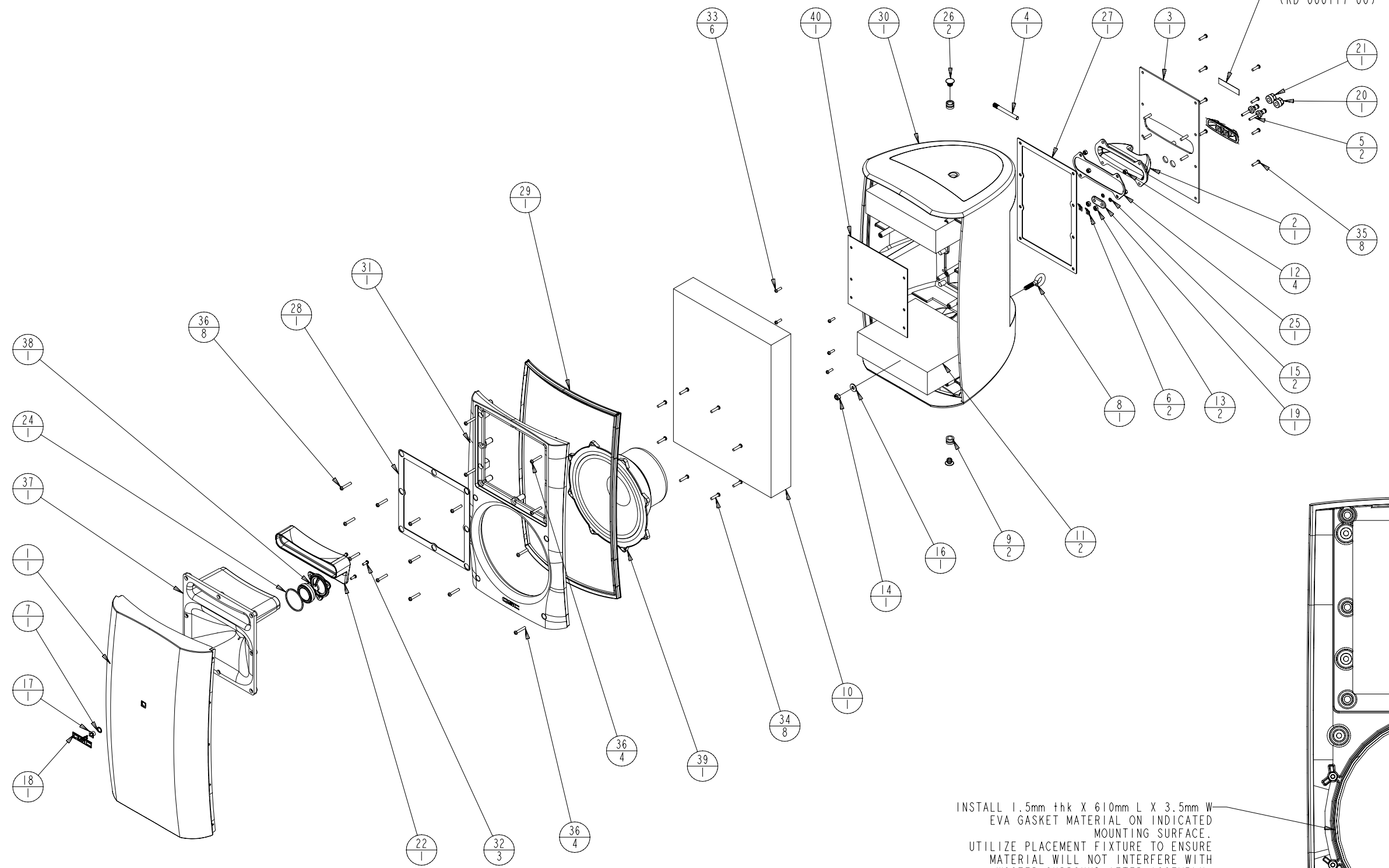

INSTALL 1.5mm thk X 610mm L X 3.5mm W
EVA GASKET MATERIAL ON INDICATED
MOUNTING SURFACE.
UTILIZE PLACEMENT FIXTURE TO ENSURE
MATERIAL WILL NOT INTERFERE WITH
WOOFER SURROUND AFTER ASSEMBLY.

SCALE 0.500

SIZE	CAGE CODE	DWG NO.	REV
D	00PW4	WP-000430-XX	B
SCALE	DRAWING INFO		SHEET
0.250	WP-000430-XX.B.1		2 of 2

DWG NO. WP-000430-XX
 SHEET 2 of 2